



# MTC

## Midi Time Code Decoder and Analyzer

M Series Module



**ELM Video  
Technology, Inc.**

*"Innovative Midi and DMX Products"*





## Table Of Contents

Important Safeguards .....	2
Product Overview .....	3
Decode Mode .....	3
Hex Mode .....	3
Switch & Connection Overview .....	4
Installation .....	5
Power and Switch Jumper .....	5
Operation .....	8
Program Mode .....	8
Decode Mode .....	8
System Exclusive Messages .....	9
Hex Mode .....	9
Scroll Layout Table .....	10
LCD Status Quadrant Table .....	10
Troubleshooting .....	12
Specifications .....	13



## Important Safeguards

Read and follow all instructions BEFORE installing or using this product.

Do not attach any product or accessories that the manufacturer does not recommend.

Keep in a well ventilated environment.

Never use or store the unit in places that are:

- Subject to temperature extremes (direct sunlight, in an enclosed vehicle, near a heating duct)

- Wet, damp and humid areas

- Dusty

- Subject to high levels of vibration

Use proper Power Sources. This product should be operated only from the type of power source indicated on the marking label or as is described in this manual.

Route power cord safely. Don't allow twists, bend the power cord, or place heavy objects on it.

Ground your equipment whenever possible.

Do not attempt to service this product unless noted otherwise.

If the unit stops working for any reason, unplug the power and other connections until repaired.

This unit should be used only with a rack or chassis that is recommended by the manufacturer.

Unplug the device when not in use.

Keep away from small children.



## **PRODUCT OVERVIEW**

The MTC is a fully input isolated Midi Time Code (MTC) signal analyzer and is part of a modular system for quick, easy and CUSTOM configuration. The MTC module receives midi time code and any (FX) clock messages from a computer or any midi instruments or device that sends MTC, decodes and displays the MTC in a clock format. By entering the "HOLD" mode, the last few messages can be viewed and scrolled through for analyzing.

Whether your a programmer, engineer, musician, or show control operator, this device and module system is ideal. The MTC filters all messages except MTC and FX messages. In conjunctions with other M series modules all midi messages can be viewed and analyzed. The MTC has flexibility with power switch jumper settings so each module can be independent or powered by one unit. The MTC has 2 receive modes of operation:

**FX - All messages that begin with hexadecimal " F " and followed by a data byte of " X " is a System Common Message or System Real-Time Message. The MTC only responds to these messages, which consists of;**

**SYSTEM COMMON MESSAGES: System Exclusive (F0), MTC (F1), Song Position Pointer (F2), Song Select (F3), Undefined (F4, F5, F9, and FD), Tune Request (F6), End of System Exclusive (F7), and**

**SYSTEM REAL-TIME MESSAGES: Timing Clock (F8), Start (FA), Continue (FB), Stop (FC), Active Sensing (FE), and Reset (FF). Note that Reset (FF) does NOT reset the module.**

*See the web sight 'Midi Manufacturers Association' for more information about MIDI messages  
( <http://www.midi.org/> )*

## **DECODE MODE**

In the Decode mode the display shows the MTC (F1) messages in a clock format. Other messages that pertain to MTC are also decoded and displayed: Full Message, User Bit, and Midi Cueing. These messages are embedded in a System Exclusive message and are decoded and displayed if the criteria is met within the message, if it is not met by the number of bytes within the message not matching the message will return as a standard System Exclusive message for analysis.

In the HOLD mode the last few bytes can be displayed and scrolled through, including a message counter. 'Midi Time Code' (F1), 'Time Clock' (F8), and 'Active Sensing (FE) messages can be selected to be filtered, An indicator shows if they are present whether they're filtered or not.

## **HEX MODE**

In the Hex mode the data is displayed in a Hexadecimal format for technical viewing, and displays the data AS IS without any decoding. In the HOLD mode the last 112 bytes can be displayed and scrolled through, including a byte counter. 'Midi Time Code' (F1), 'Time Clock' (F8), and 'Active Sensing (FE) messages can be filtered out. An indicator shows if those messages are present whether they're filtered or not.

The bottom right of the display shows errors, filter on/off, and if MTC, Timing clock and Active Sensing are present. Both modes retain 112 bytes of data that allows the user to 'HOLD' and view by scrolling left and right through the data.



## SWITCH & CONNECTION OVERVIEW

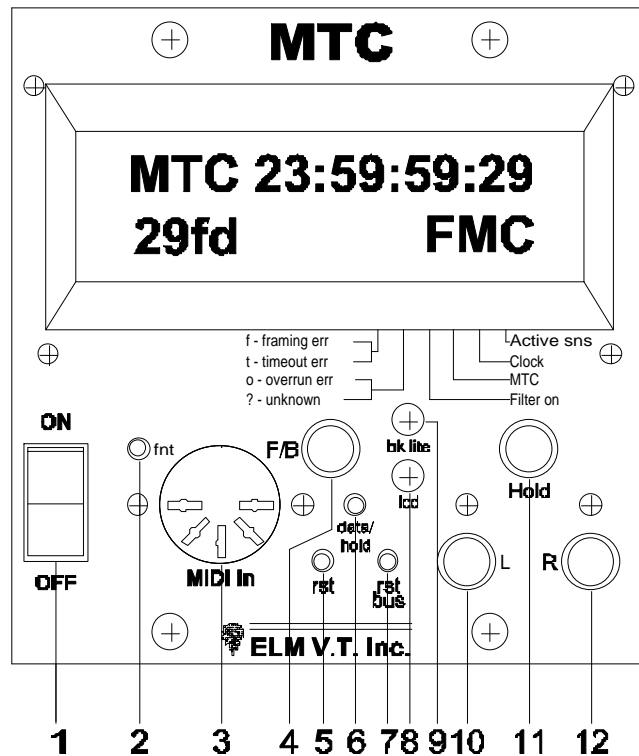

1. Power Switch - Jumper setting will determine if it will power the local module only or the local module AND the bus. (Other modules may have a jumper for using bus power or not.)
2. LED - if lit indicates the front MIDI connector is selected
3. MIDI IN - Front input.
4. INPUT SELECT - Selects Front/Rear midi input connectors Up position selects REAR connector, down selects FRONT connector for midi input.
5. RST - Resets local module only.
6. DATA/HOLD - NORMAL operation indicates data is present, constant ON indicates 'HOLD' mode.
7. RST BUS - Resets bus (or all 5 modules in the rack if applicable).
8. LCD - Liquid Crystal Display contrast adjustment.
9. BK LITE - Liquid Crystal Display BACK LIGHT brightness adjustment.
10. L - Left scroll in HOLD mode, toggles settings in PROGRAM mode.
11. HOLD - Toggles between NORMAL and HOLD mode. If pressed and held during power on or reset the MA1 will enter the PROGRAM mode.
12. R - Right scroll in HOLD mode, toggles settings in PROGRAM mode.



## Installation

### Note

\* Take care not to touch the component pins or the inner pins of the connectors. Electrostatic discharge may cause permanent damage to the unit.

Before placing the module into the M Series frame make any necessary jumper changes. For each chassis one and ONLY one module should be set up as the 'MAIN' module all other modules are considered 'SECONDARY' modules. The MAIN module has the power supply connected and supplies the other 4 SECONDARY modules the power via the BUS (ribbon cable supplied w/ the M series enclosure) or the 2 conductor Power Cable. The MAIN module can also send the received data from the MIO rear input module (sold separately) and then send the data via the ribbon cable. Or the MTC can be operated independently (not connected to the BUS). Factory jumper settings are not preset and must be properly jumpered to operate.

**Power and Switch Jumper's** - The front panel power switch (1) can be used for 2 functions. If the switch connector is plugged into J11 then the switch will toggle power to the local module only. If an MIO module (Input/Output or Power distribution module sold separately) is installed directly behind the MA1 to be installed, it is necessary to plug the switch connector into J1. (note - The power switch connector orientation does NOT matter.) This will switch the power for this module and any other module connected to the MA1 module either via the ribbon BUS cable or power connectors.

The MTC can be installed in any of the 5 module positions using (4) 6-32 screws (supplied with the M series enclosure). Once the jumper settings are made and the module is mounted flip the unit over and attach the ribbon cable and/or 2 conductor power cable (supplied with the M series Enclosure), to the other modules within the chassis, note the polarizing plug faces the edge of the board on the Ribbon cable connector (J5). Install a blank panel on the back behind the MTC if it's a secondary module or install an MIO module directly behind the MTC if it is the main module. Secure the module on the rear using (4) 6-32 screws (supplied with the M series enclosure).

Never use any modified or other modules other than genuine ELM V.T. Inc. modules.

Never allow 2 power supplies to run in parallel or 2 'Data Outputs' (J9) to be connected at the same time within a chassis.

### Power Setting EXAMPLE 1

Power supplied to this local module and to any module(s) connected via the power connector. The switch will control all modules connected via either the BUS or Power connector.

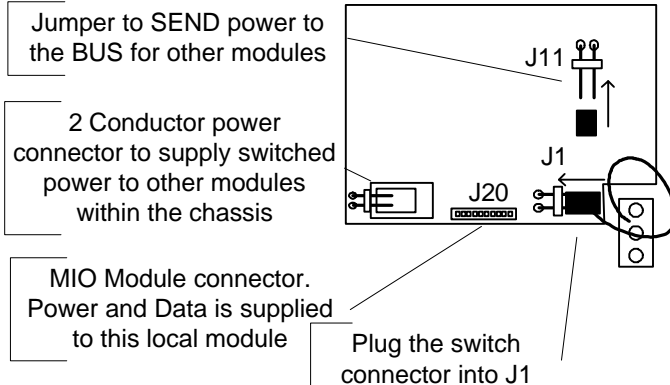

### Power Setting EXAMPLE 2

Switch turns power on/off to this local module and any modules connected to the Power Connector.

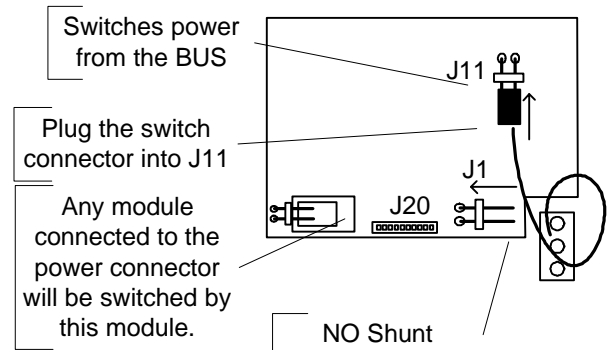

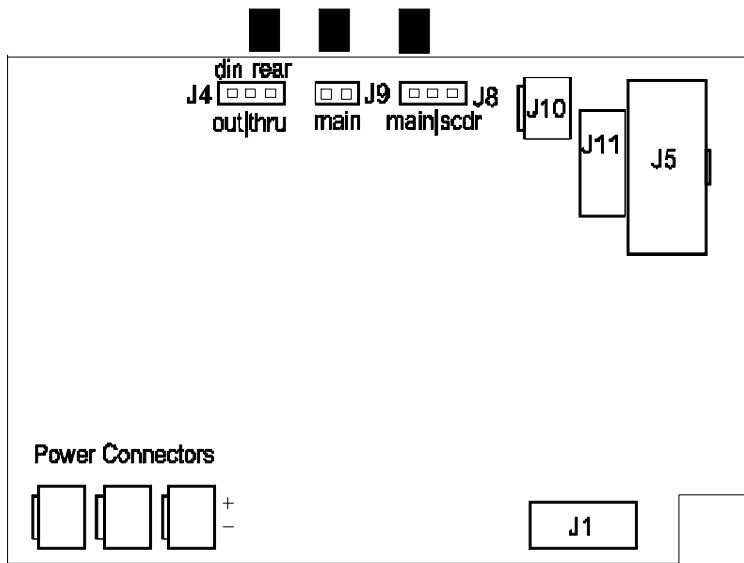

## JUMPER SETTINGS:

- J1 Power IN Switch connector
- J11 Power TO/FROM bus or Switch power from the bus to the local module
- J4 Rear Din Connector 'OUT' or 'THRU' setting
- J5 Ribbon (Bus) cable connector
- J8 Data input select - Jumper 'S' if secondary, 'M' if main
- J9 Data output to ribbon cable (only 1 per chassis should be connected)

J4 - Jumper J4 in the 'THRU' position if the REAR input Din Connector data is to be echoed (Data on the output is the SAME as the data coming in on the rear input.) Jumper to the 'OUT' position if the DIN INPUT SELECT SWITCH (Front/Rear Din Connectors selector) data should be echoed. (Data on the output is the same data that is SELECTED by the front selector switch. NOTE that if the BUS selection is made in the software that this data will NOT be sent to the output.)

J8 - Jumper J8 Jumper to 'MAIN' if the MA1 is the main unit, jumper to 'SDR' if the MA1 is used as the secondary unit.

J9 - Jumper J9 jumper if the MA1 is the main unit, this sends data to the bus to supply the secondary modules with midi data. ONLY 1 unit per chassis should have J9 jumpered.



UNPLUG the power source BEFORE attaching power and data cables. After making the necessary jumper settings, use the 6-32 screws to mount the unit in the desired position. If the module is to be the 'MAIN' module it is recommended (but optional) to place it in the left most position. From the back, plug the 10 pin ribbon cable in the PCB connector (J5) if there is another module in the chassis that has a Ribbon Cable connector and attach the power cable harness to any module within the chassis that only has a 2 conductor power connector. Both can be used. The power connector can be attached to the MIO module to supply power to any module with a 2 conductor power connector input for unswitched power. If the 2 conductor power cable is connected to a module and that module has a switch then the power will be turned on/off via the switch. After installing, inspect the ribbon cable for proper alignment before applying power. Then mount the MA1 rear panel using the 6-32 screws.

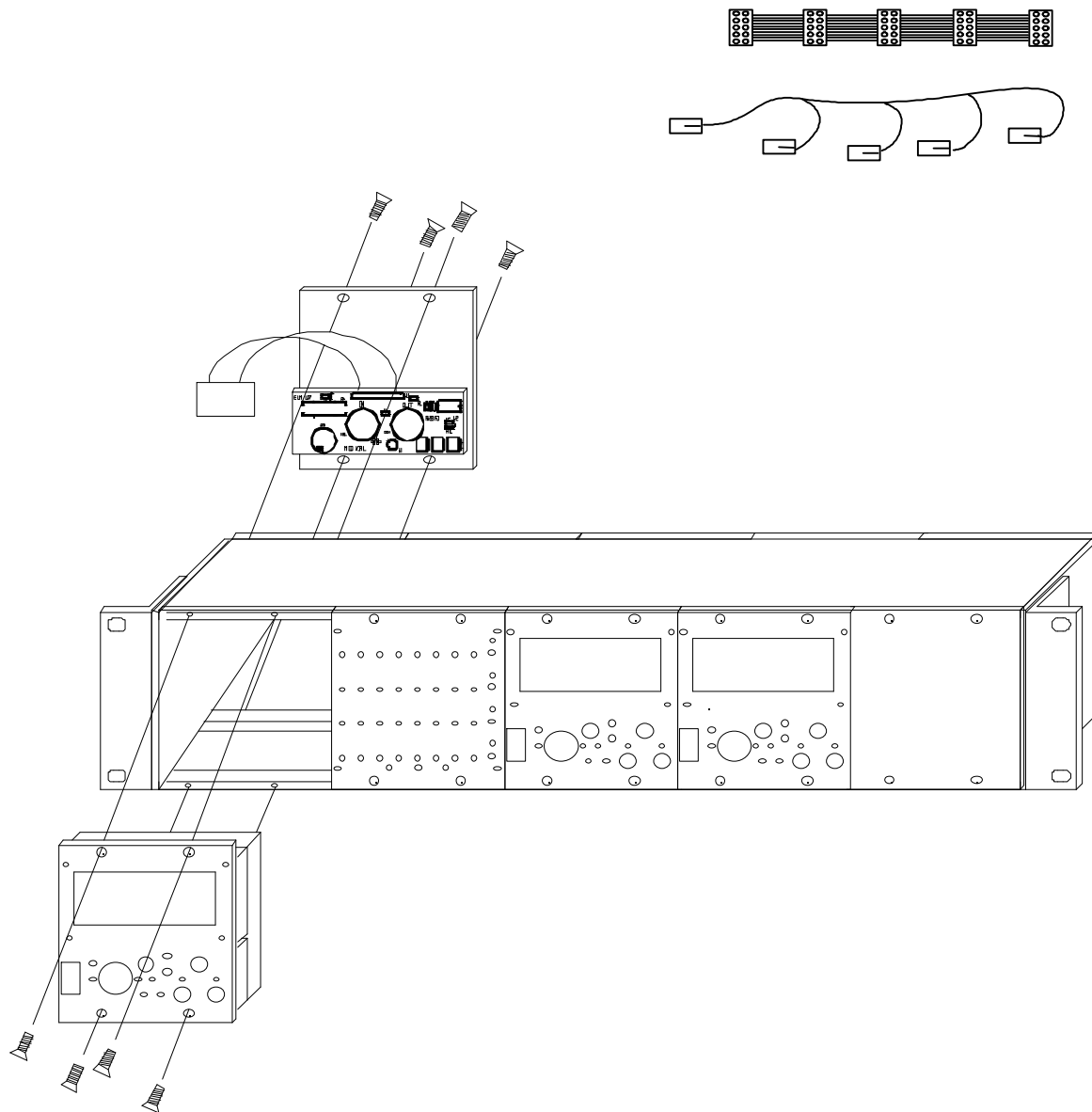

## Operation

After the jumpers are set and assembly is complete power the module. There are 2 modes of operation **PROGRAM** and **RECEIVE** mode. In the receive mode there are 2 modes: DECODE and HEX, selected in the program mode. The module powers in a receive mode. Within these modes the last messages or bytes can be viewed by pressing the 'hold' button (11) and the user can scroll the data by using the Left (10) and Right (12) buttons. There are 3 midi data inputs: the din connector on the back, the din connector on the front, and the internal BUS which is sent from the module in the chassis that is set up as the 'MAIN' unit. To toggle between the DIN's and the BUS inputs press the 'hold' (11), 'left' (10) and 'right' (12) buttons and reset (5) the module. The selected input will be displayed in the upper right until the 1st message is received. If DIN is selected the FRONT/BACK switch (4) will toggle these connectors respectively. If the front is selected the red LED will be lit. Note that a complete MTC message is actually eight bytes combined, when viewing the MTC in the HOLD mode, each message is broken down into the eight messages. Full Message, User Bit, and Midi Cueing messages are decoded and displayed as one message.

**PROGRAM MODE** - To enter the pgm mode press and hold the 'HOLD' button and reset or toggle the power. Once in the pgm mode the current setting is displayed in the lower right. To exit the pgm mode at any time press and hold the 'HOLD' button for 2 seconds or press the reset button. The programmed setting can be toggled by pressing the left or right button. The change is stored IMMEDIATELY (what you see is the stored setting). Press HOLD to advance to the next option. The last display displays the software version. Note \*\* No midi data will be received while in the pgm mode.

**Decode or Hex Mode** - Selects the operational mode, 'Decode mode' decodes the incoming data, 'Hex mode' displays the incoming data in a hexadecimal format without decoding.

**Filter F1** - If YES is selected no 'Midi Time Code' (F1) message is received or stored.

**Filter F8** - If YES is selected no 'Time Clock' (F8) message is received or stored.

**Filter FE** - If YES is selected no 'Active Sensing' (FE) message is received or stored.

**Data LED** - If ON is selected, all data traffic is shown (except 'Midi Time Code' (F1), 'Time Clock' (F8), and 'Active Sensing (FE) messages). If OFF is selected the LED is used ONLY to display the HOLD mode.

**Restore Defaults** - Select 'yes' to load the factory default settings. The settings will be stored and the unit will return to a receive mode.

**Display Software Version** - The displayed page shows the product type and software version. To exit press hold.

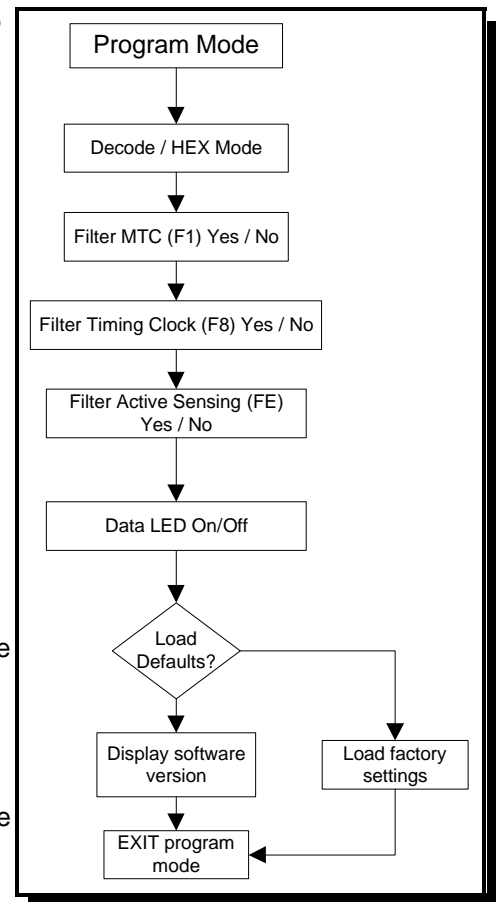

**DECODE MODE** - The decode mode is selected in the program mode. Within the decode mode there is 2 modes of operation; Display and Hold mode. In the **Display** mode all incoming MTC data will be decoded and displayed. For the standard "F1 XX" messages the data is displayed;

Quadrant:

1. MTC in clock format
2. Number of Frames and (n)non (d)drop
3. received midi message's status\*  
see LCD STATUS QUADRANT TABLE 1

**LCD MTC Receive Display**





\* An 'M' = MSB (Most Significant Byte) and an 'L' = LSB (Least Significant Byte). If followed by; an 'h' indicates hexadecimal format data.

By pressing the 'HOLD' button the unit enters the **Hold** mode. The LED indicator will come on. The display will be HOLD the current LCD display and has not yet entered the "scrollable" HOLD mode. This allows the user to stop the incoming messages without decoding the last F1 XX message, the time is held for viewing. If the LEFT or RIGHT button is pressed the module will enter the "scrollable" HOLD mode and will display the last received message. By pressing the **Hold** button again will resume the receiving of data.

While in the HOLD mode the left and right buttons will allow the user to scroll through the data. The arrows indicate more data is present in that direction. The byte number is displayed on the right side of the LCD (e.g. "# 03" ). The type of message and hexadecimal data is displayed for each message stored, (the last message received is message 1). The message number will increase as you scroll left and decrease as you scroll right for all messages.

**System Exclusive Messages (F0)** - If the message is a Sys Ex message and it matches the criteria (see Sys Ex Criteria Tables) for Midi Time Code' (F1), 'Time Clock' (F8), and 'Active Sensing (FE), then the message is decoded and displayed accordingly. If the message doesn't meet the criteria the message is displayed as a standard System Exclusive message and is displayed differently. Quadrant 1 displays the

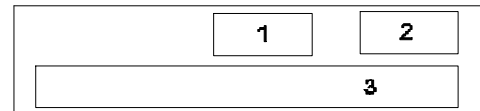

total number of bytes in the Sys EX message. Quadrant 2 displays the **BYTE** number directly above that byte. Quadrant 3 is the System Exclusive data. Once a Sys Ex message is displayed the scrolling option will change. If the Sys Ex message has more than 7 bytes (which is the display range) then the right arrow will be on, if you scroll right it will show the 8th byte within the Sys Ex message. Once your in a Sys Ex display range the arrows indicate the direction of data in that range unless your at the head or end of the range indicated by an 'F0 or 'F7', if so it will advance to the next message. Note that there is NOT a message counter displayed, only a BYTE counter while displaying a Sys Ex message.

No data is received during HOLD.

See [Scroll layout table](#) for scrolling description.

**HEX MODE** - The hex mode is selected in the program mode. Within the decode mode there are 2 modes of operation; **Display** and **Hold** mode. In the **Display** mode all FX MIDI data will be displayed in hexadecimal format. All other types of messages are ignored. The newest byte of data will be displayed in the upper right of the display. In this mode only 3 types of data can be filtered: Midi Time Code (F1), Timing Clock (F8), and Active Sensing (FE).

Quadrant:

1. incoming hex data, newest byte far right
2. MTC received midi message's status

See [LCD Status Quadrant Table](#)

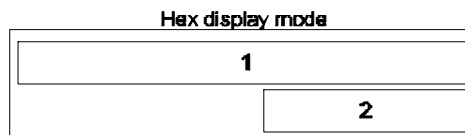

By pressing the 'HOLD' button enters the **Hold** mode. The LED indicator will come on. The hex data is shifted to the bottom row. The lower right byte is the last byte received. The upper right will show the byte number of the byte directly below. The left and right buttons will scroll through the data. The arrows indicate more data is present in that direction. The byte number will increase as you scroll left and decrease as you scroll right. The data is display exactly as it was received. No data is received during HOLD. See [Scroll layout table](#) for scrolling description.

Quadrant:

1. byte number of the byte below
2. MA1 and received midi message's status

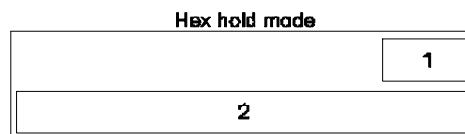



## LCD STATUS QUADRANT TABLE

position	display	Indication	Clears by	Note
1	'f'	framing error has occurred - occurs if there is an incoming data error, either powered the unit or switched modes and a message was already in progress, or could indicate a unstable connection.	reset, or check wiring or sending device	
1	't'	time out error has occurred - occurs if there is more than 2 milli second delay between bytes before a message is complete.	reset	this error is overridden by the 'framing' error
2	'?'	unknown message has been received - incorrect number of bytes received, either to many or to little.	reset	
2	'o'	overrun error has occurred - to much data is received with special features turned on such as Filtering, Running status & Real time messages (F8 - FE) which require more processing. If this error occurs - limit these features/functions. *	reset	this error is overridden by the '?' unknown message error
3	'F'	Filter is ON - any or all filters are active. Enter the program mode to show which ones are on.	pgm mode filter options	
4	'M'	Midi Time Code is being received.	midi sending device	
5	'C'	Timing clock is being received.	"	
6	'A'	Active Sensing is being received.	"	

*\*(Known overflow condition example (hex) 83 24 F8 F9 FA FB FC FD FE FF 7F FFE FE FE , ALL THESE INSERTED W/ ANY 8X - EX FILTER ON, CAUSES AN OVERFLOW AND IF MORE ARE SENT CAUSES A FRAMING ERROR TOO. (INSERT TEST B 7TH TX))*

Scroll Layout Table				
LEFT	<-----	message	(or byte #)	increases
<b>END</b>	<b>oldest msg (or byte)</b>	<b>up to 112 msg's (or bytes)</b>	<b>newest msg (or byte)</b>	<b>END</b>
message	(or byte #)	decreases	----->	RIGHT

## Sys Ex Criteria

# MTC Midi Time Code



**ELM Video  
Technology, Inc.**  
"Innovative Midi and DMX Products"

For the following messages to be decoded they must meet the following criteria, otherwise they are displayed as a System Exclusive Message. The "match =" column is the hexadecimal number that is accepted as the match criteria. If it does not match exactly or fall within the range the message is rejected and shown as a Sys Ex Message. Even though the ranges are accepted the data has to be within the message specifications or the message will display as "UNDEFINED" or will be incorrect displayed. Some of the message bytes are not decoded for displaying the "Shown" column tells if it is shown; Yes / No.

## Full Message or Full Frame 10 Byte Message

#	Byte	Match =	Decimal	Description	Shown
1	F0	F0		System Exclusive	N
2	7F	00-7F	0-127	Header	N
3	cc	00-7F	0-127	Sys Ex Channel number	Y
4	01	01		Sub ID 1	N
5	01	01		Sub ID 2	N
6	hr/type	00-7F	0-127	Hour and (Frame) Type	Y
7	mn	00-7F	0-127	Minutes	Y
8	sc	00-7F	0-127	Seconds	Y
9	fr	00-7F	0-127	Frames	Y
10	F7	F7		End of System Exclusive	N

## User Bit 15 Byte Message

#	Byte	Match =	Decimal	Description	Shown
1	F0	F0		System Exclusive	N
2	7F	00-7F	0-127	Header	N
3	cc	00-7F	0-127	Sys Ex Channel number	Y
4	01	01		Sub ID 1	N
5	02	02		Sub ID 2	N
6	U1	00-7F	0-127	User bit nibble 1	Y
7	U2	00-7F	0-127	User bit nibble 2	Y
8	U3	00-7F	0-127	User bit nibble 3	Y
9	U4	00-7F	0-127	User bit nibble 4	Y
10	U5	00-7F	0-127	User bit nibble 5	Y
11	U6	00-7F	0-127	User bit nibble 6	Y
12	U7	00-7F	0-127	User bit nibble 7	Y
13	U8	00-7F	0-127	User bit nibble 8	Y
14	U9	00-7F	0-127	User bit nibble 9	Y
15	F7	F7		End of System Exclusive	N



## Midi Cueing 13 Byte Message plus any Additional Information

#	Byte	Match =	Decimal	Description	Shown
1	F0	F0		System Exclusive	N
2	7E	00-7F	0-127	Header	N
3	cc	00-7F	0-127	Sys Ex Channel number	Y
4	04	04		Sub ID 1	N
5	02	02		Sub ID 2	N
6	hr/type	00-7F	0-127	Hour and (Frame) Type	Y
7	mn	00-7F	0-127	Minutes	Y
8	sc	00-7F	0-127	Seconds	Y
9	fr	00-7F	0-127	Frames	Y
10	ff	00-7F	0-127	Fractional Frames	Y
*11	sl	00-7F	0-127	Event Number Least Significant bits 6 thru 0	Y
*12	sm	00-7F	0-127	Event Number Most Significant bits 13 thru 7	Y
**	<add info>	00-7F	0-127	User bit nibble 8	Y
13	F7	F7		End of System Exclusive	N

\*\* if Sub ID 2 is = 07, 08, 0C, or 0E then the total byte length can be up to 19 bytes (6 additional information bytes) and are displayed in hexadecimal format.

\* if Sub ID 2 is = 00 then the Event Number is a Special Setup Message

## Troubleshooting

PROBLEM	CHECK
Unit won't power up Switch turns off modules I don't want turned off Switch doesn't work	verify proper switch connector settings & jumpers check power switch connections check fuse and power connections
Won't receive data on local module	verify data is being sent from source check the DIN/BUS software setting is correct make sure input switch on front panel is selected properly check that the data being sent is not being filtered
MAIN module will receive data but the SECONDARY modules do not	check that J9 is jumpered on MAIN module check that the ribbon cable is connected properly make sure that two data signals are not on the ribbon cable (see jumper settings section)
LCD is lit but there's not anything displayed	adjust the LCD contrast
Midi out connector is not sending correct data	check thru/out jumper setting
Sometimes I have a '?' or 't error when I switch from Front/Back or Din to Bus	a switch was made while a message was being sent or received, either limit the data during a switch or reset the unit after switching
Sometimes the 'A' active sense indicator turns off and back on	some devices won't send an 'active sense' message if it's sending other data, this is normal



## Specifications

Power Input	+5 volts DC
Power Consumption	.4 Amps at full power (LCD back light full brightness)
Input power connector	2.1 mm I.D. X 5.5 mm O.D. Center positive
Fuse	2.5 Amp Fast Acting 5 X 20 mm
Dimensions	3.385" Width X 3.485" Height X 1.9" Depth
Data Type	MIDI 31.5 Khz
Midi input	input 1 (rear), input 2 (front) 5 pin female DIN
Midi output	output 1 (rear) 5 pin female DIN, 20 ma output max
Memory buffer size	112 bytes (37 - 3 byte messages or 112 - 1 byte messages)
Memory Storage Cycles	10,000 times

SV 01.12 MR1