

**BEFORE PRINTING TURN OFF ANY SIZE ADJUST SETTING ON YOUR PRINTER,  
VERIFY PRINTED HOLE SIZES BEFORE DRILLING**

# DMX10V DRILL TEMPLATE

Cut and tape this template on your chassis to use a guide.  
Re space the connectors and PCB as desired.

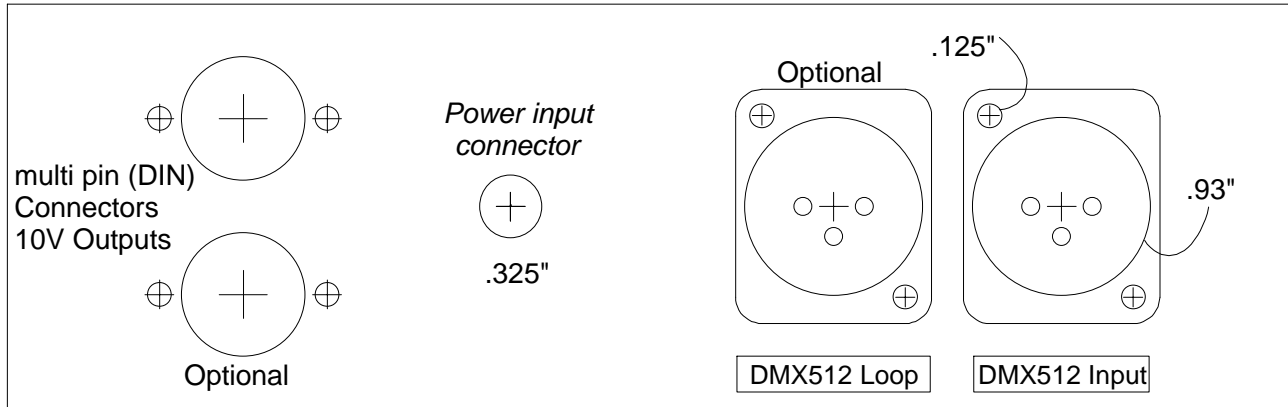

Dimensions for Neutrik 3 or 5 Pin Male/Female Chassis Mount XLR's.  
Any 3 or 5 pin XLR type can be used; chassis mount or inline.

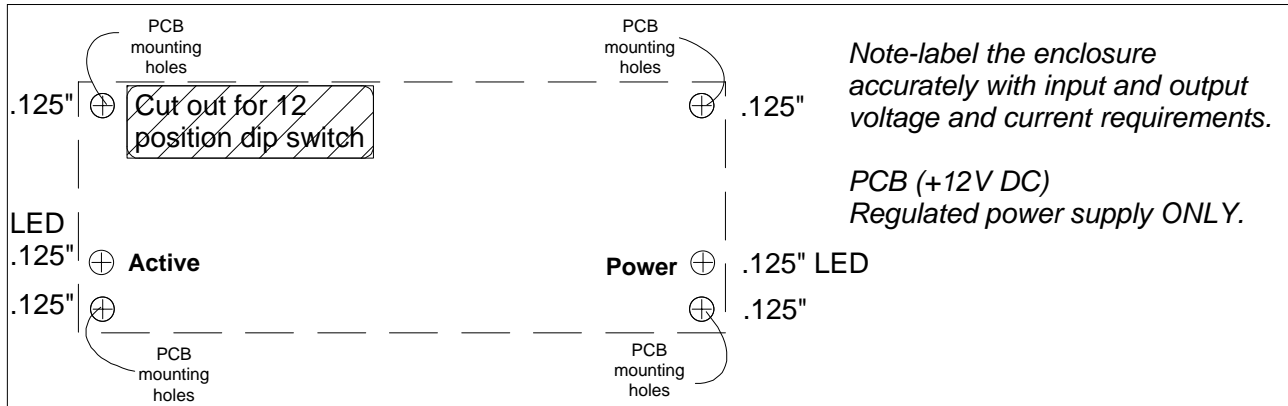

Handle the PCB with static electricity precautions -  
touch a grounded source to discharge static electricity before touching the PCB

## WIRING DIAGRAM Top View

